



Instruction Manual

Volume Booster

Model: VP1



3. DESCRIPTION

Volume Booster VP1 is one-to-one signal to output supply air, when used with a Positioner and Actuator, it is a control device to increase the stroking speed of control valves.

4. FEATURES

- Precise and fast response.
- Adjustable Sensitivity control allows this Volume Booster to meet various control valve requirements.
- Soft seats provide tight shut off to reduce unnecessary air consumption.
- Small size and light weight allow the Volume Booster to be installed directly inline without a bracket.
- Options available

5. SPECIFICATION

Model		VP1
Max Supply Pressure		1MPa
Signal and Output Pressure		0.14~0.7MPa
Signal to Output Ratio		1:1
Linearity		1%
Flow Capacity (CV)	Exhaust	1.3
	Output	1.2
Signal Port		PT(NPT)1/4
Supply / Output Port		PT(NPT)1/4
Ambient Temperature		-20°C ~70°C (Standard type)
Material		Aluminum Die Casting
Weight		0.55kg

SAFETY RECOMMENDATION

⚠ General Information

- Please ensure to read and understand the manual before installation and maintenance of the products.
- The manual should be passed to the End-User.
- When the product is not used within its description range, it may cause the product to malfunction so please follow the product manual instructions.

⚠ Handling Precautions

- Do not install, operate or maintain without being fully trained and qualified in Valve and accessory installation.
- When exceeding the permitted air pressure range, it may cause injury or property damage due to compressed air explosion. So it is very important to carefully read, understand and follow all of the contents of the relevant product manual.
- To avoid the inflow of the excessive air to the actuator, it is highly recommended to install an air filter regulator in front of the Volume Booster.

⚠ User Environment

- Do not use in corrosive environments.
- When used in environments that are a higher temperature than the specified temperature range, it may cause a lower life cycle of the product. So please ensure to use within the specified temperature range.

2. LIMITED WARRANTY AND DISCLAIMER

- The manufacturer warranty period of the product is 18 months after the product is shipped from the factory in Korea.
- For any failure or damage reported within the warranty period which is clearly our responsibility, a replacement product or necessary parts will be provided. This limited warranty applies only to our product independently, and not to any other damage incurred due to the failure of the product.
- Using the device in a manner that does not fall within the scope of its intended use, disregarding this manual, using under unqualified personnel, or making unauthorized alterations releases the manufacturer from liability for any resulting damage. This renders the manufacturer's warranty null and void.

6. PRODUCT CODE

Model	VP1		
Air Connection	PT1/4	P	
	NPT1/4	N	
Ambient Temperature	-20°C ~70°C		S
	-20°C ~120°C		H
	-40°C ~70°C		L
	-60°C ~70°C		U

7. LABEL

MODEL

Indicates the Model number

LOT NO.

Indicates the Lot number

MAX.SUP.PRESSURE 1.0MPa

Indicates Max. Supply Air Pressure

MAX.SIG./OUT.PRESSURE 0.7MPa

Indicates Max. Signal & Output Air Pressure

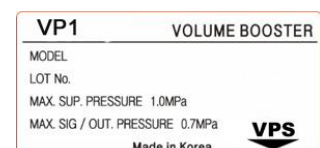

8. MATERIALS OF CONSTRUCTION

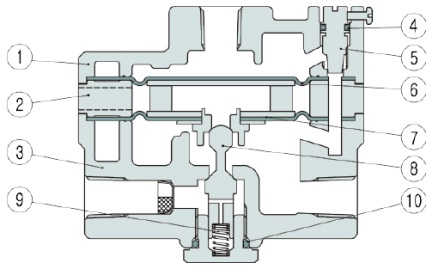

NO	TITLE	MATERIAL
1	COVER	ALDC12
2	RING EXHAUST	ALDC12
3	BODY	ALDC12
4	O-RING	NBR
5	ADJUST SCREW	STS
6	DIAPHRAGM UPPER	NBR
7	ASS'Y DIAPHRAGM	AL/NBR
8	POPPET	STS
9	SPRING SEAT	STS
10	O-RING	NBR

9. PRINCIPLE OF OPERATION

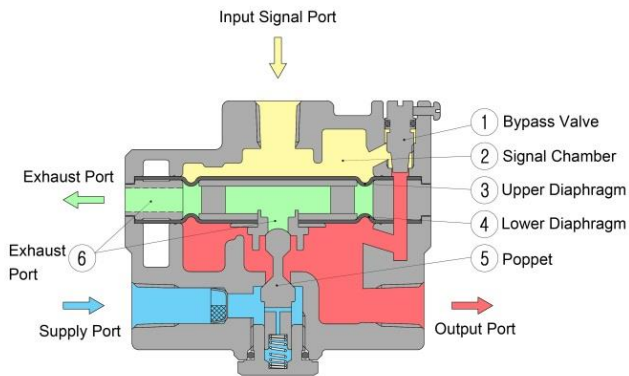

<Sectional View >

When the Input Signal to Supply Air to the actuator increases, Supply Air of Signal Chamber (2) and the pressure of the Upper Diaphragm (3) increase. The differential pressure at the Lower Diaphragm (4) causes the poppet to move downward and open, providing Supply Air through the Poppet (5) Lower seat line and Output Port to the Actuator. In contrast, when the Input Signal to Supply Air to the actuator decreases, it causes the Poppet Upper seat to open. The Supply Air in the actuator is released via the Exhaust Port (6). When the Input Signal Air and Output Supply Air are equalized at 1:1 ratio, the Poppet will move to the original position and block upper and lower seats to keep the current position of the Output Supply Air. The Bypass Valve (1) is used to adjust the response of the pneumatic volume booster to match the closed control loop safety. The Sensitivity of Output Supply Air to Input Signal can be adjusted by controlling Bypass Valve. (High and Low Temperature)

10. BRACKET INSTALLATION

If you need to install bracket, you can make the bracket by referring to product dimension drawings, and please install it as below.

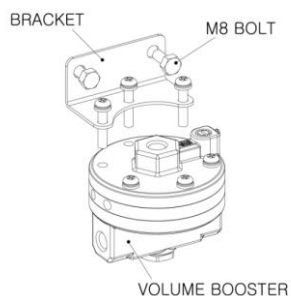

11. PNEUMATIC CONNECTION

- ① Connect the Positioner's Output Port with the Volume Booster's SIGNAL Port.
- ② Connect the Volume Booster's OUTPUT Port with the Actuator.
- ③ Connect the supply air to the SUPPLY Port and install an adequate size Air Filter Regulator that guarantee the Volume Booster's Output Supply Air pressure.

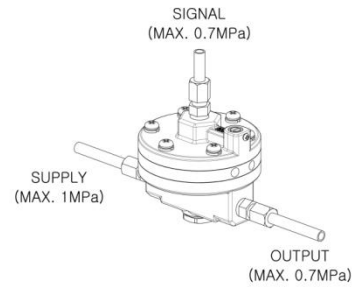

12. INSTALLATION EXAMPLE

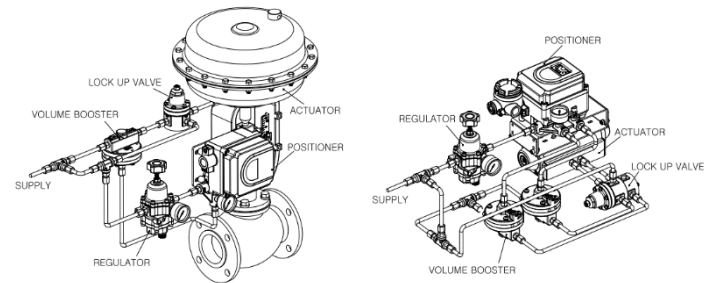

<Single Acting Linear Actuator>

<Double Acting Rotary Actuator>

13. DIMENSION (Unit : mm)

